

T7030
T7040
T7050
T7060

OPERATOR'S MANUAL



NEW HOLLAND

Electro-magnetic Interference (EMC)

This tractor complies strictly with the European Regulations on electro-magnetic emissions. However, interference may arise as a result of add-on equipment which may not necessarily meet the required standards. As such interference can result in serious malfunction of the unit and/or create unsafe situations, you must observe the following:

- Ensure that each piece of non-New Holland equipment fitted to the tractor bears the CE mark.
- The maximum power of emission equipment (radio, telephones, etc.) must not exceed the limits imposed by the national authorities of the country where you use the tractor.
- The electro-magnetic field generated by the add-on system should not exceed 24 V/m at any time and at any location in the proximity of electronic components.

Failure to comply with these rules will render the New Holland warranty null and void.

CONTENTS

Title	Page
Section 1 - General Information and Safety	
To the Owner	1-1
End User License Agreement	1-2
Product Identification	1-3
Ecology and the Environment	1-6
Safety Precautions	1-7
Safety Decals	1-14
International Symbols	1-19
Airborne Noise Emission	1-20
Section 2 - Controls, Instruments and Operation	
Cab	2-4
Electrical Power Sockets	2-19
Seats	2-22
Handbrake, Throttle and Foot Controls	2-30
Instrument Console	2-32
Analogue/Digital Instruments	2-35
Power Command Transmission	2-67
Differential Lock and Four Wheel Drive	2-87
Section 3 - Field Operation	
Important Information	3-2
Boosting the Tractor Battery	3-4
Starting the Engine	3-5
Stopping the Engine	3-8
Engine Power Management	3-10
Engine Speed Management	3-11
Headland Turn Sequence	3-13
Fast Steer	3-24
Rear Power Take-Off	3-26
Front Power Take-Off and Hydraulic Lift	3-40
Electronic Draft Control	3-57
Load Sensing Remote Control Valves	3-69
Electronic Remote Control Valves	3-75
Electro-Hydraulic Remote Control Valves	3-75
Three-point Hitch	3-93
Quick Hitch	3-99
Linkage Stabilisers	3-103
Drawbars and Towing Attachments	3-106
Trailer Braking Systems	3-119
Front Wheel Track Adjustment	3-126
Rear Wheel Track Adjustment	3-134
Ballasting and Tyres	3-144

Section 4 - Lubrication and Maintenance

General Information	4-1
Guard Removal	4-5
Lubrication and Maintenance Chart	4-10
Servicing: When Warning Lights Illuminate	4-11
10-hour/daily service	4-15
50-hour service	4-17
100-hour service	4-30
300-hour service	4-29
600-hour service	4-33
1200-hour/12 month service	4-40
1200-hour/24 month service	4-46
Every 3 years	4-54
General Maintenance - as required	4-55
Storing the tractor	4-73

Section 5 - Fault Finding

Introduction	5-1
Engine	5-4
Transmission	5-7
Hydraulics	5-8
3-point hitch	5-9
Brakes	5-10
Cab	5-10
Electrical	5-11

Section 6 - Accessories

Intelliview II Monitor	6-2
Engine Coolant Immersion Heater	6-3
Transmission Oil Heater	6-3
Rotating Beacon	6-4
Auxiliary Headlights	6-4
40 Amp Socket and Cable	6-5
Battery Isolator Switch	6-6
Dynamic Front Fenders	6-7

Section 7 - Specification

General Dimensions 7-2

Vehicle Weights 7-5

Lubricant and Fluid Capacities 7-6

Engine 7-7

Fuel System 7-7

Cooling System 7-8

Transmission Options 7-8

Maximum Operating Angle 7-9

Rear Power Take-Off 7-9

Front Power Take-Off 7-9

Hydraulic System 7-10

Three-Point Lift 7-10

Remote control valves 7-14

Front 3-Point Hitch 7-14

Front Remote Valves 7-14

Brakes 7-15

Steering 7-15

Electrical Equipment 7-16

Hardware Torque Tables 7-17

Section 8 - First 50-hour Service Forms 8-1

Section 9 - Index 9-1

SECTION 1

GENERAL INFORMATION AND SAFETY

TO THE OWNER

GENERAL

This Manual has been prepared to assist you in the correct procedure for running-in, driving and operating and for the maintenance of your new tractor. Read this Manual carefully. Your tractor is intended for use in normal and customary agricultural applications.

If at any time you require advice concerning your tractor, do not hesitate to contact your authorised dealer. He has factory trained personnel, genuine manufacturers' parts and the necessary equipment to carry out all your service requirements.

Your tractor has been designed and built to give maximum performance, economy and ease of operation under a wide variety of operating conditions. Prior to delivery, the tractor was carefully inspected, both at the factory and by your dealer to ensure that it reaches you in optimum condition. To maintain this condition and ensure trouble-free operation, it is important that the routine services, as specified in Section 4 of this Manual, are carried out at the recommended intervals.

OPERATORS MANUAL STORAGE

A storage pocket for the Operators Manual can be found on the rear of the seat. The manual should be kept in this pocket at all times when not in use.

CLEANING THE TRACTOR

Your tractor is a state-of-the-art machine with sophisticated, electronic controls. This should be taken into consideration when cleaning the tractor, particularly if using a high pressure washer. Even though every precaution has been taken to safeguard electronic components and connections, the pressure generated by some of these machines is such that complete protection against water ingress cannot be guaranteed.

When using a high pressure washer, do not stand too close to the tractor and avoid directing the jet at electronic components, electrical connections, breathers, seals, filler caps, etc. Never direct a cold water jet at a hot engine or exhaust.

SAFETY

Pages 1-7 to 1-13 inclusive list the precautions to be observed to ensure your safety and the safety of others. Read the safety precautions and follow the advice offered **before** operating the tractor.

FIRST 50 HOUR SERVICE

In Section 8, at the back of this Manual, you will find the 50-hour service reports.

After you have operated the tractor for 50 hours, take your tractor, together with this Manual, to your dealer. He will then perform the factory recommended 50 hour service and complete the service report sheets (pages 8-1 and 8-3). The first sheet (page 8-1) is the dealer's copy and should be removed by the dealer after the service has been carried out. The second sheet (page 8-3) is your copy of the service performed. **Ensure that you and the dealer sign both copies.**

SERVICE PARTS

It should be pointed out that genuine parts have been examined and approved by the Company. The installation and/or use of 'non-genuine' products could have negative effects upon the design characteristics of your tractor and thereby affect its safety. The Company is not liable for any damage caused by the use of 'non-genuine' parts and accessories. Only genuine New Holland replacement parts should be used. The use of non-genuine parts may invalidate legal approvals associated with this product.

It is prohibited to carry out any modifications to the tractor unless specifically authorised, in writing, by the After Sales Service department of the Company.

WARRANTY

Your tractor is warranted according to legal rights in your country and the contractual agreement with the selling dealer. No warranty shall, however, apply if the tractor has not been used, adjusted and maintained according to the instructions given in the Operator's Manual.

END USER LICENCE AGREEMENT TERMS

- You have acquired a device ("DEVICE") that includes Software licensed by CHN America LLC from Microsoft Licensing, GP or its affiliates ("MS"). Those installed software products of MS origin, as well as associated media, printed materials, and "online" or electronic documentation ("SOFTWARE") are protected by international intellectual property laws and treaties. The SOFTWARE is licensed, not sold. All rights reserved.
- IF YOU DO NOT AGREE TO THIS END USER LICENSE AGREEMENT ("EULA"), DO NOT USE THE DEVICE OR COPY THE SOFTWARE. INSTEAD, PROMPTLY CONTACT CNH AMERICA LLC FOR INSTRUCTIONS ON RETURN OF THE UNUSED DEVICE(S) FOR A REFUND. **ANY USE OF SOFTWARE INCLUDING BUT NOT LIMITED TO USE ON THE DEVICE, WILL CONSTITUTE YOUR AGREEMENT TO THIS EULA (OR RATIFICATION OF ANY PREVIOUS CONSENT.)**
- **GRANT OF SOFTWARE LICENSE.** This EULA grants you the following license:
 - You may use the SOFTWARE only on the DEVICE.
 - **NOT FAULT TOLERANT.** THE SOFTWARE IS NOT FAULT TOLERANT. CNH AMERICA LLC HAS INDEPENDENTLY DETERMINED HOW TO USE THE SOFTWARE IN THE DEVICE, AND MS HAS RELIED UPON CNH AMERICA LLC TO CONDUCT SUFFICIENT TESTING TO DETERMINE THAT THE SOFTWARE IS SUITABLE FOR SUCH USE.
 - NO WARRANTIES FOR THE SOFTWARE. THE SOFTWARE is provided "AS IS" and with all faults. THE ENTIRE RISK AS TO SATISFACTORY QUALITY, PERFORMANCE, ACCURACY AND EFFORT (INCLUDING LACK OF NEGLIGENCE) IS WITH YOU. ALSO, THERE IS NO WARRANTY AGAINST INTERFERENCE WITH YOUR ENJOYMENT OF THE SOFTWARE OR AGAINST INFRINGEMENT. **IF YOU HAVE RECEIVED ANY WARRANTIES REGARDING THE DEVICE OR THE SOFTWARE, THOSE WARRANTIES DO NOT ORIGINATE FROM, AND ARE NOT BINDING ON, MS.**
 - No Liability for Certain Damages. **EXCEPT AS PROHIBITED BY LAW, MS SHALL HAVE NO LIABILITY FOR ANY INDIRECT, SPECIAL, CONSEQUENTIAL OR INCIDENTAL DAMAGES ARISING FROM OR IN CONNECTION WITH THE USE OR PERFORMANCE OF THE SOFTWARE. THIS LIMITATION SHALL APPLY EVEN IF ANY REMEDY FAILS OF ITS ESSENTIAL PURPOSE. IN NO EVENT SHALL MS BE LIABLE FOR ANY AMOUNT IN EXCESS OF U.S. TWO HUNDRED AND FIFTY DOLLARS (U.S. \$250.00)**
 - **Limitations on Reverse Engineering, Decompilation, and Disassembly.** You may not reverse engineer, decompile, or disassemble the SOFTWARE, except and only to the extent that such activity is expressly permitted by application law notwithstanding this limitation.
 - **SOFTWARE TRANSFER ALLOWED BUT WITH RESTRICTIONS.** You may permanently transfer rights under this EULA only as part of a permanent sale or transfer of the DEVICE, and only if the recipient agrees to this EULA. If the SOFTWARE is an upgrade, any transfer must also include all prior versions of the SOFTWARE.
 - **EXPORT RESTRICTIONS.** You acknowledge that SOFTWARE is subject to U.S. export jurisdiction. You agree to comply with all applicable international and national laws that apply to the SOFTWARE, including the U.S. Export Administration Regulations, as well as end-user, end-use and destination restrictions issued by U.S. and other governments. For additional information see <http://www.microsoft.com/exporting/>.

PRODUCT IDENTIFICATION

The tractor and major components are identified using serial numbers and/or manufacturing codes. Tractor identification data must be supplied to the dealer when requesting parts or service and will also be needed to aid in identifying the tractor if it is ever stolen.

The following provides the locations of the identification data.

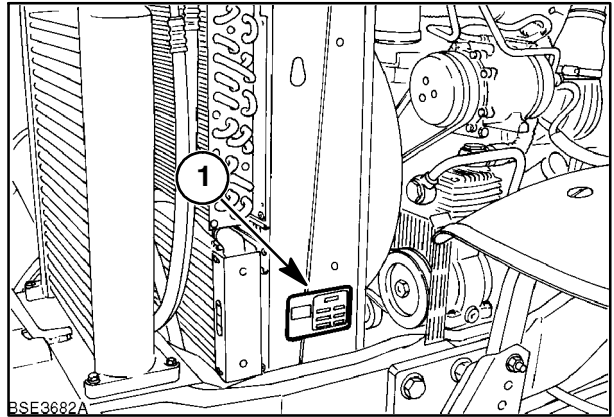

1

Vehicle Identification Plate

The vehicle identification plate, (1) Figure 1 is located on the left-hand radiator support. Record the information on the sample identification plate provided below.

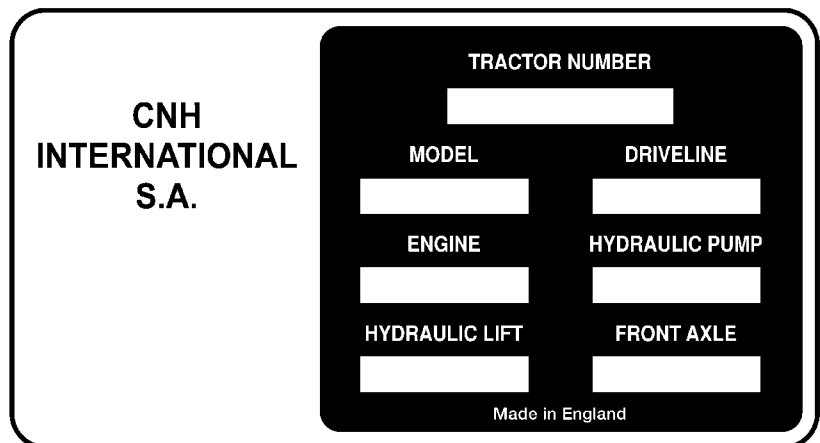

2

Tractor Identification

The serial number and model identification information is stamped on the right-hand side of the front support (1). These numbers are also repeated on the vehicle identification plate reproduced above.

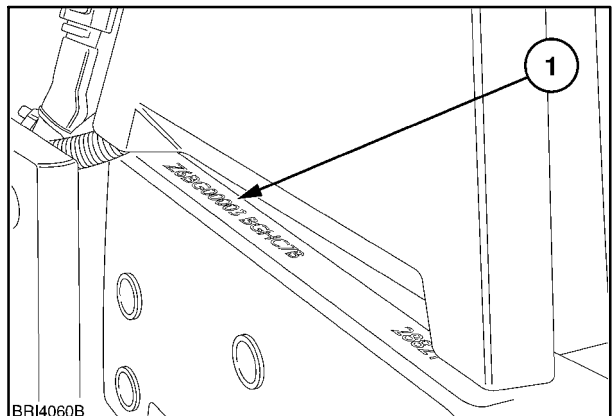

3

SECTION 1 - GENERAL INFORMATION AND SAFETY

Engine Information

The engine serial number and date of manufacture are stamped on the engine information plate (1) located on the left side of the engine oil pan.

Engine Serial No. _____

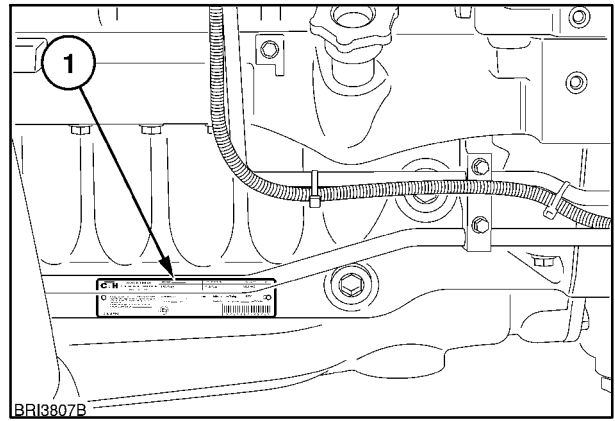

4

Further information relating to engine adjustments and emission level compliance are also shown on the engine information plate.

<p>CNH U.K. Limited IMPORTANT ENGINE INFORMATION Assembled in U.K.</p> <p>The engine conforms to _____ US E.P.A. & C.A.R.D. regulations for large non-road compression engines. When making adjustments set parking brake and block wheels. This engine designed to operate on diesel fuel Emission Control System</p> <p>Date of MFG _____</p>	C/O Litre _____	Engine Serial No. _____	FELg/kW hr _____	EPA _____
	E.P.A. Family _____	Model Type _____	NOx NMHC _____	
	GROSS Rated HP/kW _____ rpm	Engine Model _____	PM _____	
	Valve lash cold (mm) _____ Int _____ Exh _____	Initial Injection Timing _____ BTDC _____		
	Low Idle _____ rpm	Fuel rate adv. power _____ mm ³ /stroke		
			X X X X X X X X X X X X X X X X	

Driveline Identification

The serial number plate (1) is located on the transmission casing. Access to the number can be gained by removing the plate in the floor of the cab as shown in the illustration. This number is repeated on the vehicle identification plate. Record the information below for quick reference.

Driveline Serial No. _____

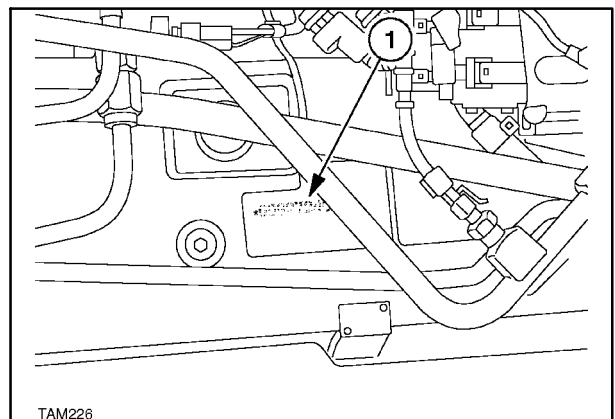

5

Cab Identification

The cab serial number and other information is on the OECD certification plate. This plate can be found on the right-hand side of the cab trim panel, below the rear window. Record the cab serial number below for quick reference.

Cab Serial No. _____

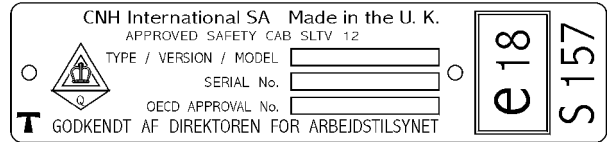

6

Vehicle Weight Information

The Vehicle Weighting Plate provides important information on tractor and towed equipment weight combinations. This plate can be found on the right-hand side of the cab trim panel, below the rear window.

The figures shown are the maximum permissible weights and should not be exceeded, to do so may affect the safe operation of the tractor.

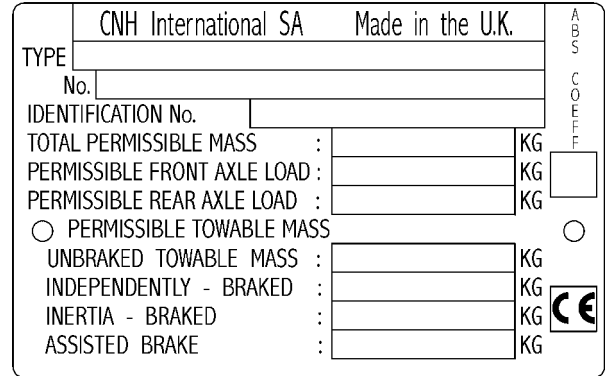

7

ECOLOGY AND THE ENVIRONMENT

Soil, air and water are vital factors of agriculture and life in general. Where legislation does not yet rule the treatment of some of the substances which are required by advanced technology, common sense should govern the use and disposal of products of a chemical and petrochemical nature.

The following are recommendations which may be of assistance:

- Become acquainted with and ensure that you understand the relative legislation applicable to your country.
- Where no legislation exists, obtain information from suppliers of oils, filters, batteries, fuels, anti freeze, cleaning agents, etc., with regard to their effect on man and nature and how to safely store, use and dispose of these substances. Agricultural consultants will, in many cases, be able to help you as well.

HELPFUL HINTS

1. Avoid filling tanks using unsuitable containers or inappropriate pressurised fuel delivery systems which may cause considerable spillage.
2. In general, avoid skin contact with all fuels, oils, acids, solvents, etc. Most of them contain substances which can be harmful to your health.
3. Modern oils contain additives. Do not burn contaminated fuels and/or waste oils in ordinary heating systems.
4. Avoid spillage when draining off used engine coolant mixtures, engine, gearbox and hydraulic oils, brake fluids, etc. Do not mix drained brake fluids or fuels with lubricants. Store them safely until they can be disposed of in a proper way to comply with local legislation and available resources.
5. Modern coolant mixtures, i.e. antifreeze and other additives, should be replaced every two years. They should not be allowed to get into the soil but should be collected and disposed of safely.
6. Do not open the air-conditioning system yourself. It contains gases which should not be released into the atmosphere. Your dealer or air conditioning specialist has a special extractor for this purpose and will have to recharge the system anyway.
7. Repair any leaks or defects in the engine cooling or hydraulic system immediately.
8. Do not increase the pressure in a pressurised circuit as this may lead to the components exploding.
9. Protect hoses during welding as penetrating weld splatter may burn a hole or weaken them, causing the loss of oils, coolant, etc.

SAFETY PRECAUTIONS

A careful operator is the best operator. Most accidents can be avoided by observing certain precautions. To help prevent accidents, read and take the following precautions **before** driving, operating or servicing the tractor. Equipment should be operated only by those who are responsible and instructed to do so.

PRECAUTIONARY STATEMENTS

Throughout this Manual you will see text, preceded by the words **NOTE**, **ATTENTION**, **IMPORTANT**, **CAUTION**, **WARNING** or **DANGER**. Such text has the following significance:

MACHINE SAFETY

NOTE: This text stresses a correct operating technique or procedure.

ATTENTION: This text warns the operator of potential machine damage if a certain procedure is not followed.

IMPORTANT: This text informs the reader of something that he needs to know to prevent minor machine damage if a certain procedure is not followed.

PERSONAL SAFETY



The word **CAUTION** is used where a safe behavioural practice, according to operating and maintenance instructions and common safety practices will protect the operator and others from accident involvement.



The word **WARNING** denotes a potential or hidden hazard which could possibly cause serious injury. It is used to warn operators and others to exercise due care and attention to avoid a surprise accident with machinery.



The word **DANGER** denotes a forbidden practice in connection with a serious hazard.

Failure to follow the **CAUTION**, **WARNING** and **DANGER** instructions may result in serious bodily injury or even death.

THE TRACTOR

1. Read the Operator's Manual carefully before using the tractor. Lack of operating knowledge can lead to accidents.
2. Only allow properly trained and qualified persons to operate the tractor.
3. To prevent falls, use the handrails and step plates when getting on and off the tractor. Keep steps and platform clear of mud and debris.
4. Replace all missing, illegible or damaged safety decals.
5. Keep safety decals free of dirt or grime.

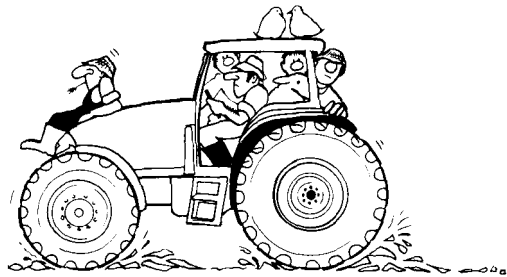

6. Do not permit anyone but the operator to ride on the tractor except for driver training or instruction. When used for these purposes an additional seat may be fitted in the cab. Passengers should not be carried on the tractor at any time.
7. Keep children away from the tractor and farm machinery at all times.
8. Do not modify or alter or permit anyone else to modify or alter the tractor or any of its components or any tractor function without first consulting your dealer.
9. Install all guards before starting the engine or operating the tractor.

DRIVING THE TRACTOR

1. Always sit in the driver's seat while starting or driving the tractor.
2. When driving on public roads, have consideration for other road users. Pull in to the side of the road occasionally to allow any following traffic to pass. Do not exceed the legal speed limit set in your country for agricultural tractors.
3. Use a rotating beacon and/or Slow Moving Vehicle warning when driving on public roads to indicate that the vehicle is slow moving and is a possible hazard.
4. Dip the tractor lights when meeting a vehicle at night. Make sure the lights are adjusted to prevent blinding the driver of an oncoming vehicle.
5. Reduce speed before turning or applying the brakes. Brake both wheels simultaneously when making an emergency stop. Ensure that both brake pedals are locked together when travelling at road speeds or when on public roads to ensure correct operation of trailer brakes, balanced operation of the tractor brakes and four wheel braking (4WD tractors only).



6. On four wheel drive tractors, the drive to the front axle is automatically engaged, to provide four wheel braking, when both footbrakes are applied. Owners should be aware of the effectiveness of four wheel braking which greatly enhances braking performance. Appropriate care should be exercised during fierce braking.
7. Use extreme caution and avoid hard application of the tractor brakes when towing heavy loads at road speeds.

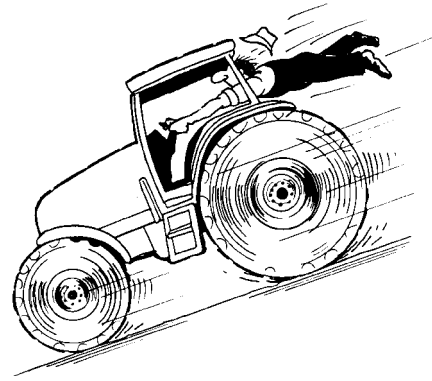

8. Keep the tractor in the same gear when going downhill as would be used when going uphill. Do not coast or freewheel down hills.
9. For safe operation any towed vehicle whose total weight exceeds that of the towing tractor must be equipped with a braking system that complies with the legal requirements of that country.
10. Never apply the differential lock when turning. When engaged, the differential lock will prevent the tractor from turning.
11. Always check overhead clearance, especially when transporting the tractor. Watch where you are going, especially at row ends, on roads and around trees and low overhanging obstacles.
12. To avoid overturns, drive the tractor with care and at speeds compatible with safety, especially when operating over rough ground, when crossing ditches or slopes and when turning corners.

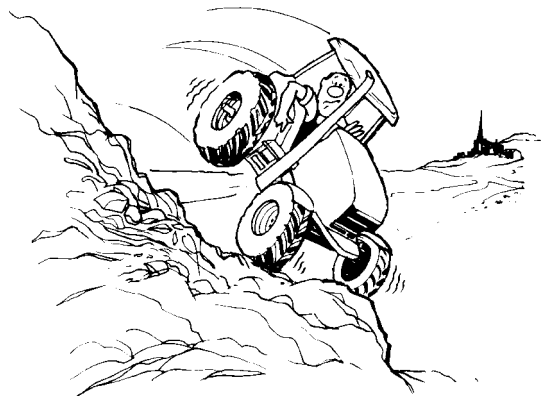

13. Use extreme caution when operating on steep slopes.
14. If the tractor becomes stuck or the tyres are frozen to the ground, reverse the tractor out to prevent overturning.

OPERATING THE TRACTOR

1. Apply the parking brake, place the P.T.O. control in the 'OFF' position, the lift control lever in the down position, the remote control valve levers in the neutral position and the transmission levers in neutral before starting the tractor.
2. Do not start the engine or operate controls (other than externally located hydraulic lift or P.T.O. switches, if fitted) while standing beside the tractor. Always sit in the tractor seat when starting the engine or operating the controls.
3. Do not bypass the transmission and P.T.O. neutral start switches. Consult your authorised dealer if your neutral start controls malfunction. Use jump leads only in the recommended manner. Improper use can result in a tractor runaway.



4. Avoid accidental contact with the gear shift levers while the engine is running. Unexpected tractor movement can result from such contact.
5. Do not get off the tractor while it is in motion.
6. If the power steering or engine ceases operating, stop the tractor immediately as the tractor will be more difficult to control.
7. Before leaving the tractor, park the tractor on level ground, apply the parking brake, lower attached implements to the ground, disengage the P.T.O. and stop the engine.

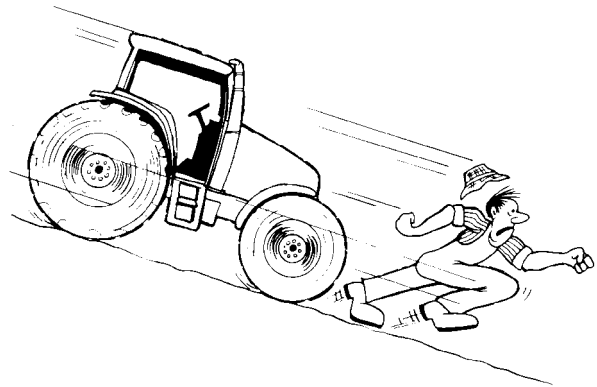

8. Do not park the tractor on a steep incline.
9. The cab is designed to provide the minimum noise level at the operator's ears and meets or exceeds applicable standards in this respect. However, noise (sound pressure level) in the workplace can exceed 85 dB(A) when working between buildings or in confined spaces, with cab windows open. Therefore, it is recommended that operators wear suitable ear protectors when operating in high noise level conditions.

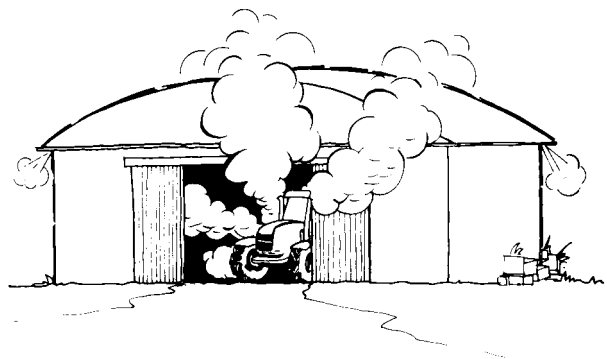

10. Do not run the tractor engine in an enclosed building without adequate ventilation. Exhaust fumes are toxic and can cause death.
11. Pull only from the pick-up hitch, swinging drawbar or the lower link drawbar in the lowered position. Use only a drawbar pin that locks in place. Pulling from the tractor rear axle or any point above the axle may cause the tractor to overturn.

12. Always select Position Control when attaching equipment and when transporting equipment. Be sure hydraulic couplers are properly mounted and will disconnect safely in case of accidental detachment of the implement.

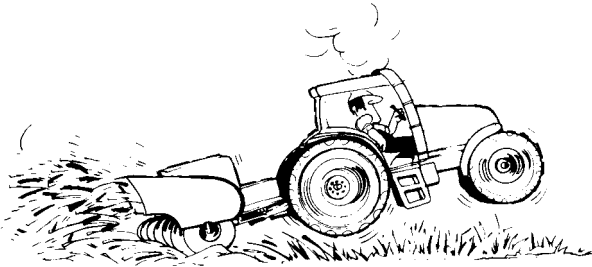

13. If the front end of the tractor tends to rise when heavy implements are attached to the three-point hitch, install front end or front wheel weights. Do not operate the tractor with a light front end.
14. Engage the clutch slowly when driving out of a ditch, gully or up a steep hillside. Disengage the clutch promptly if the front wheels rise off the ground.
15. Ensure any attached equipment or accessories are correctly installed, are approved for use with the tractor, do not overload the tractor and are operated and maintained in accordance with the instructions issued by the equipment or accessory manufacturer.
16. Remember that your tractor, if abused or incorrectly used, can be dangerous and become a hazard both to the operator and to bystanders. Do not overload or operate with attached equipment which is unsafe, not designed for the particular task or is poorly maintained.
17. Do not leave equipment in the raised position when the vehicle is stopped or unattended.
18. Do not drive equipment near open fires.
19. Always wear a protective mask when working with toxic spray chemicals. Follow the directions on the chemical container.

OPERATING THE P.T.O.

1. When operating P.T.O.- driven equipment, shut off the engine, switch off the P.T.O. and wait until the P.T.O. stops before getting off the tractor and disconnecting the equipment.

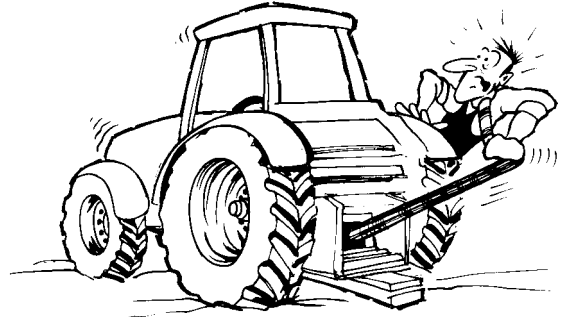

2. Do not wear loose clothing when operating the power take-off or especially when near rotating equipment.
3. When operating stationary P.T.O.-driven equipment, always apply the tractor parking brake and block the rear wheels front and back.



4. To avoid injury, do not clean, adjust, unclog or service P.T.O. driven equipment when the tractor engine is running. Ensure that the P.T.O. is switched off.
5. Make sure the P.T.O. guard is in position at all times and always replace the P.T.O. cap when the P.T.O. is not in use.

SERVICING THE TRACTOR



1. The cooling system operates under pressure which is controlled by the expansion tank cap. It is dangerous to remove the cap while the system is hot. Always turn the cap slowly to the first stop and allow the pressure to escape before removing the cap entirely. Never remove the cap from the top of the radiator unless the expansion tank pressure cap has first been removed.
2. Do not smoke while refuelling the tractor. Keep any type of open flame away.
3. Keep the tractor and equipment, particularly brakes and steering, maintained in a reliable and satisfactory condition to ensure your safety and comply with legal requirements.
4. To prevent fire or explosion, keep open flames away from battery or cold weather starting aids. To prevent sparks which could cause explosion, use jumper cables according to instructions.
5. Do not attempt to service the air conditioning system. It is possible to be severely frost bitten or injured by escaping refrigerant. Special equipment and instruments are required to service the air conditioning system. See your authorised dealer for service.
6. Stop the engine before performing any service on the tractor.
7. Hydraulic fluid and fuel oil in the injection system operate under high pressure. Escaping hydraulic fluid or fuel oil under pressure can penetrate the skin causing serious injury.

Unqualified persons should not remove or attempt to adjust a pump, injector, nozzle or any other part of the fuel injection or hydraulic systems. Failure to follow these instructions can result in serious injury.

- Do **not** use your hand to check for leaks. Use a piece of cardboard or paper to search for leaks.
- Stop the engine and relieve pressure before connecting or disconnecting lines.



- Tighten all connections before starting the engine or pressurising lines.
 - If fluid is injected into the skin obtain medical attention immediately or gangrene may result.
8. Do not modify or alter or permit anyone else to modify or alter the tractor or any of its components or any tractor function without first consulting an authorised dealer.
 9. Continuous long term contact with used engine oil may cause skin cancer. Avoid prolonged contact with used engine oil. Wash skin promptly with soap and water.
 10. Keep equipment clean and properly maintained.
 11. Dispose of all drained fluids and removed filters properly.
 12. Tractor wheels are very heavy. Handle with care and ensure, when stored, that they cannot topple and cause injury.

DIESEL FUEL

1. Under no circumstances should gasoline, alcohol or blended fuels be added to diesel fuel. These combinations can create an increased fire or explosive hazard. In a closed container such as a fuel tank these blends are more explosive than pure gasoline. Do not use these blends.
2. Never remove the fuel cap or refuel with the engine running or hot.
3. Do not smoke while refuelling the tractor or when standing near fuel. Keep any type of open flame away.
4. Maintain control of the fuel filler pipe nozzle when filling the tank.
5. Do not fill the fuel tank to capacity. Fill only to the bottom of the filler neck to allow room for expansion.
6. Wipe up spilled fuel immediately.
7. Always tighten the fuel tank cap securely.
8. If the original fuel tank cap is lost, replace it with an approved cap. A non-approved cap may not be safe.
9. Never use fuel for cleaning purposes.
10. Arrange fuel purchases so that summer grade fuels are not held over and used in the winter.



**WHENEVER YOU SEE THIS SYMBOL  IT MEANS: ATTENTION!
BECOME ALERT! YOUR SAFETY IS INVOLVED!**

OPERATOR PROTECTIVE STRUCTURE



Your machine is equipped with an operator Protective Structure, such as: a Roll Over Protective Structure (ROPS) or Falling Object Protective Structure (FOPS) or Cab with ROPS. A ROPS may be a cab frame or a two-posted or four-posted structure used for the protection of the operator to minimise the possibility of serious injury.

The Protective Structure is a special safety component of your machine.

DO NOT attach any device to the Protective Structure for pulling purposes. DO NOT drill holes to the Protective Structure.

The Protective Structure and interconnecting components are a certified system. Any damage, fire, corrosion or modification will weaken the structure and reduce your protection. If this occurs, the **Protective Structure MUST be replaced** so that it will provide the same protection as a new Protective Structure. Contact your dealer for Protective Structure inspection and replacement.

After an accident, fire, tip or roll over, the following **MUST** be performed by a qualified technician before returning the machine to field or job site operation.

- The Protective Structure **MUST be replaced**.
- The mounting or suspension for the Protective Structure, operator seat and suspension, seat belts and mounting components and wiring within the operator's protective system **MUST** be carefully inspected for damage.
- All damaged parts **MUST be replaced**.

DO NOT WELD, DRILL HOLES, ATTEMPT TO STRAIGHTEN OR REPAIR THE PROTECTIVE STRUCTURE. MODIFICATION IN ANY WAY CAN REDUCE THE STRUCTURAL INTEGRITY OF THE STRUCTURE WHICH COULD CAUSE DEATH OR SERIOUS INJURY IN THE EVENT OF FIRE, TIP, ROLL OVER, COLLISION OR ACCIDENT.

SAFETY DECALS

The decals reproduced on the following pages were installed on your tractor in the positions indicated in the drawings below. They are intended for your safety and for those working with you. Please take this Manual and walk around your tractor, noting the location of the decal and their significance. Review the decals and operating instructions detailed in this Manual with the machine operators. Keep the decals clean and legible. If they become damaged or illegible, obtain replacements from your authorised dealer.

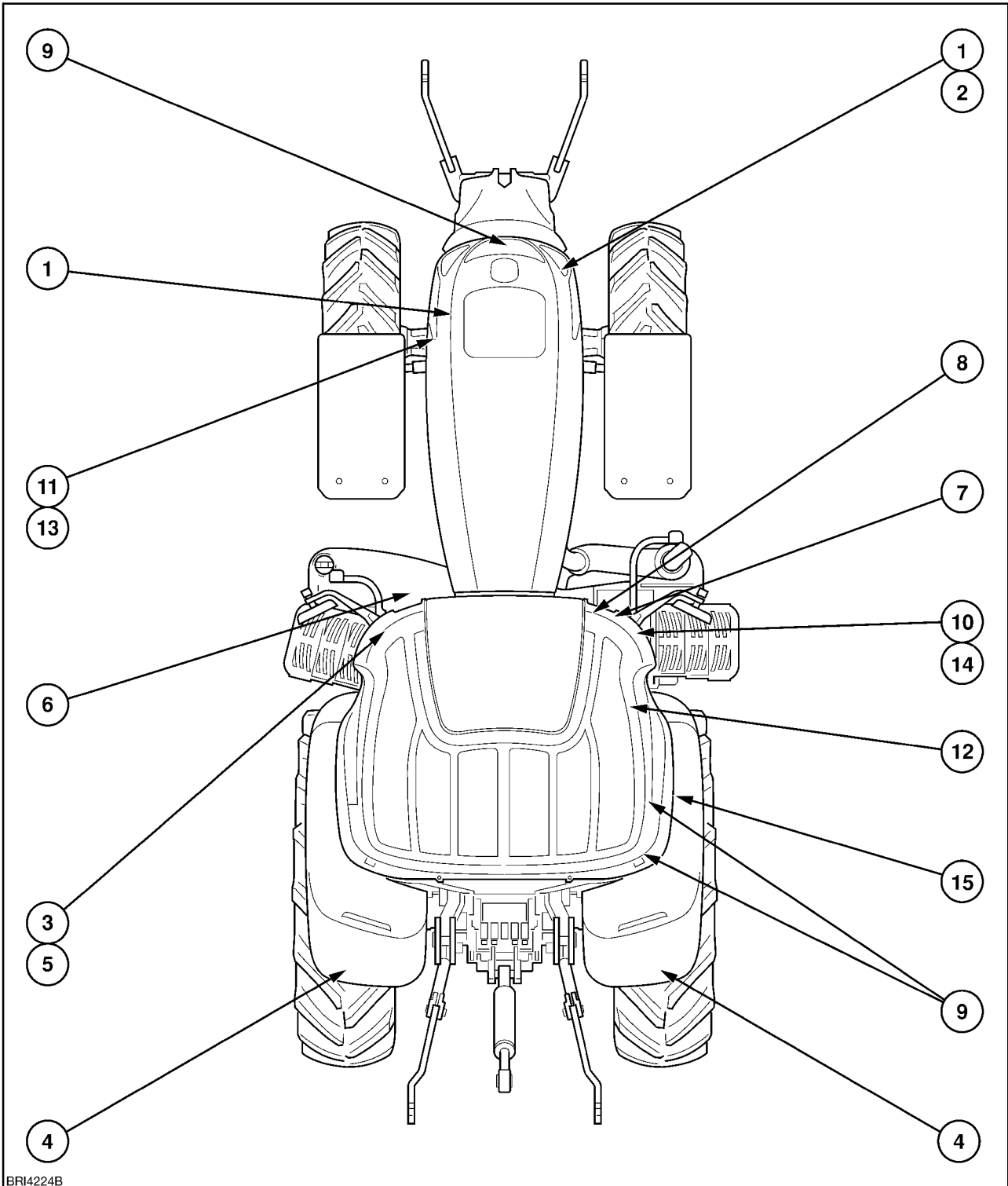

**Thanks very much for your reading,
Want to get more information,
Please click here, Then get the complete
manual**

JustClickHere 

NOTE:

**If there is no response to click on the link above,
please download the PDF document first, and then
click on it.**

**Have any questions please write to me:
admin@servicemanualperfect.com**